

S S 1 5<sup>®</sup>



MADE IN U.S.A.

 **allied**  
TUBE & CONDUIT  
FENCE DIVISION  
A tyco INTERNATIONAL LTD. COMPANY



## Fence Framework is ideal for a wide variety of applications:

- Athletic Enclosures
- Controlled Access Fencing
- Dog Kennels
- Private Parking Lots
- Residential Framework
- Security Partitions

For long-lasting strength you can rely on, specify Allied SS-15 fence framework!

Allied SS-15 fence framework is manufactured from superior strength cold-formed steel with

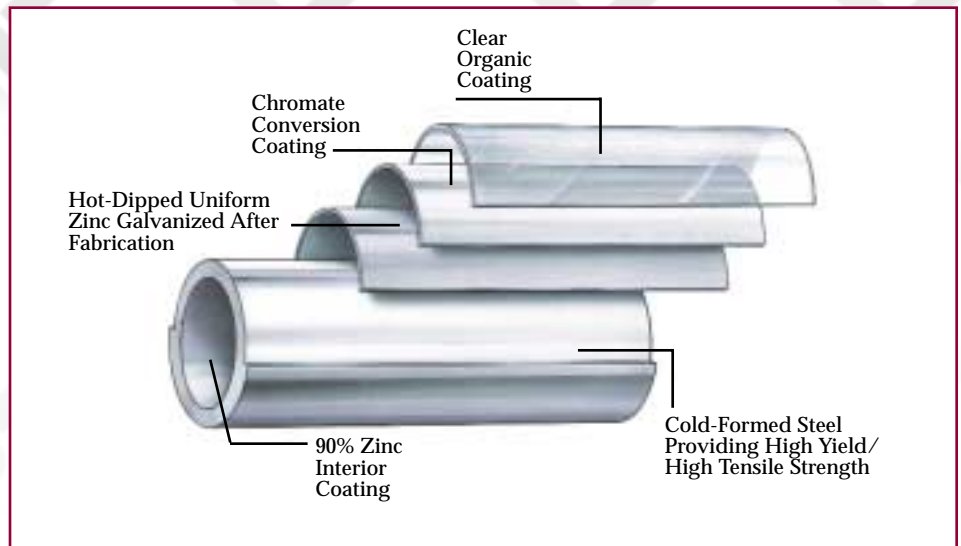

a yield strength of 50,000 PSI. It is then given Allied's patented Flo-Coat® triple layer protection of zinc, a conversion coating and a clear organic topcoat to assure unequaled

durability and resistance to corrosion and environmental attack.

Allied SS-15 is available in stock lengths of 21 ft. and 24 ft. Other lengths are available upon request.

Sizes available:

### Physical Dimensions and Strength Calculations SS-15 Pipe Sizes

| Fence Industry Size O.D. | Decimal Equivalent (O.D.) |       | Weight  |        | Minimum Yield Strength | Pieces per Bundle |
|--------------------------|---------------------------|-------|---------|--------|------------------------|-------------------|
|                          | inches                    | (mm)  | lb./ft. | (kg/m) |                        |                   |
| 1-3/8                    | 1.315                     | 33.40 | 0.957   | 1.424  | 50,000                 | 91                |
| 1-5/8                    | 1.660                     | 42.16 | 1.222   | 1.819  | 50,000                 | 61                |
| 2                        | 1.900                     | 48.26 | 1.407   | 2.094  | 50,000                 | 61                |
| 2-1/2                    | 2.375                     | 60.33 | 1.773   | 2.638  | 50,000                 | 37                |

Specifications, descriptions, and illustrated material are accurate as known at time of publication and are subject to change without notice.

*Allied Tube & Conduit makes no warranties with respect to its products, whether expressed, written or implied, including any warranty of merchantability or of fitness for a particular purpose.*

Call Anchor Fence Wholesalers of Miami at:

# 305-691-7711

or visit our website at [www.AnchorMiami.com](http://www.AnchorMiami.com)

E-Mail: [sales@AnchorMiami.com](mailto:sales@AnchorMiami.com)



MEMBER



Anchor Fence Wholesalers  
3670 NW 79th St. Miami, FL  
Phone: 305-691-7711  
Fax: 305-693-1386